

SERIES: IP-PRO

- Well over-thought and super simple construction
- Reduction of mechanical gearbox sound
- 32% reduction in weight compared with standard IP-175
- Quicker and easier maintenance solutions
- Inspection/service of valves without usage of spanners
- Less needs for exchange by valve blockage/leaking
- Reduction in shaft power input, less energy consumption

=

HIGHER FINANCIAL OUTPUT

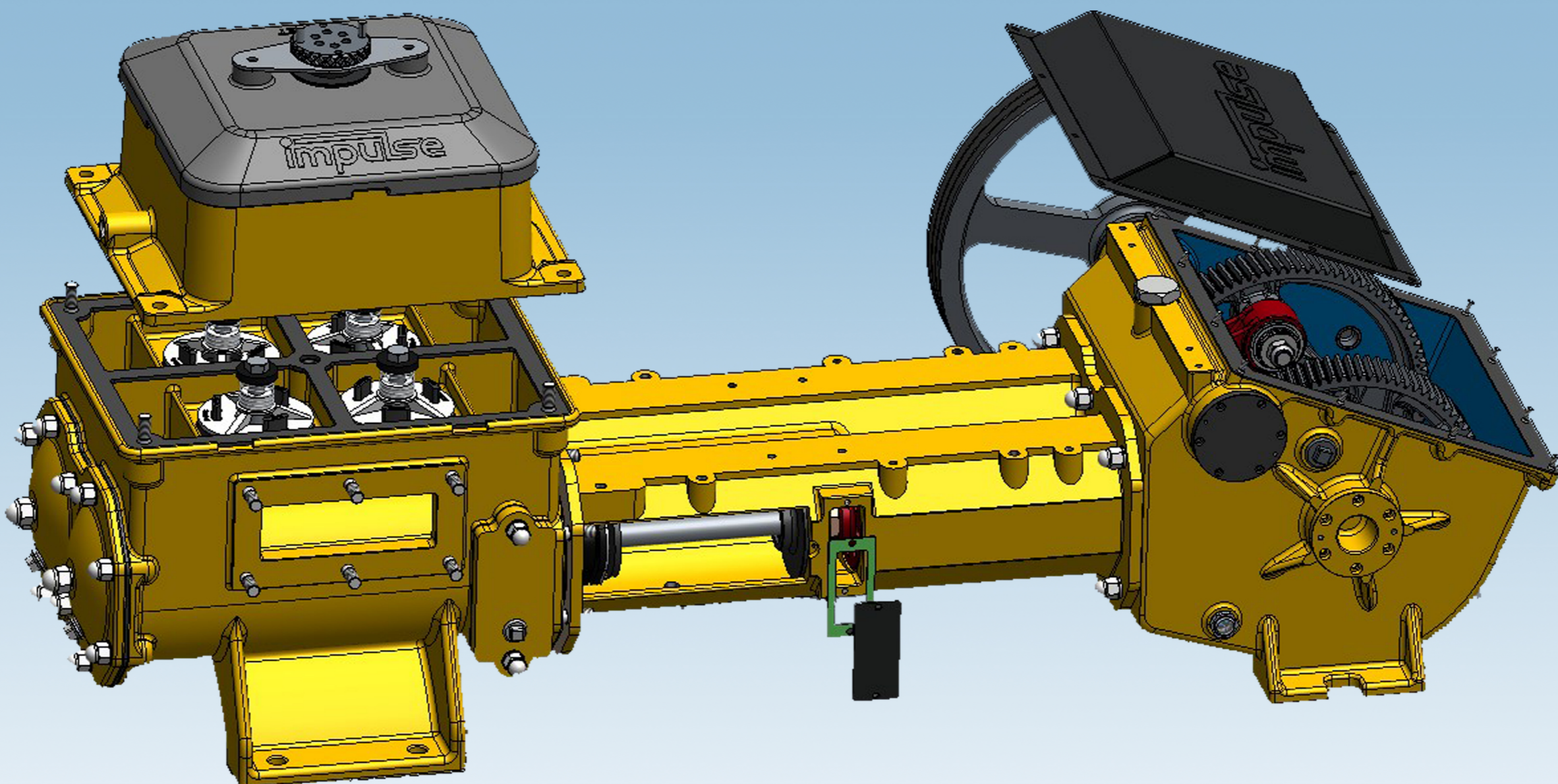

Impossible to live without water...